

# STOL CH 750

SUPER DUTY SPORT UTILITY AIRCRAFT



\* UnPanel display available as a kit option

MAX STOL  
MAX UTILITY

Swing-Up Full Bubble Doors / Windows

Increases Cabin Width to 50 inches!  
Superb downward visibility

Rear Jump Seat / Large Cargo Area

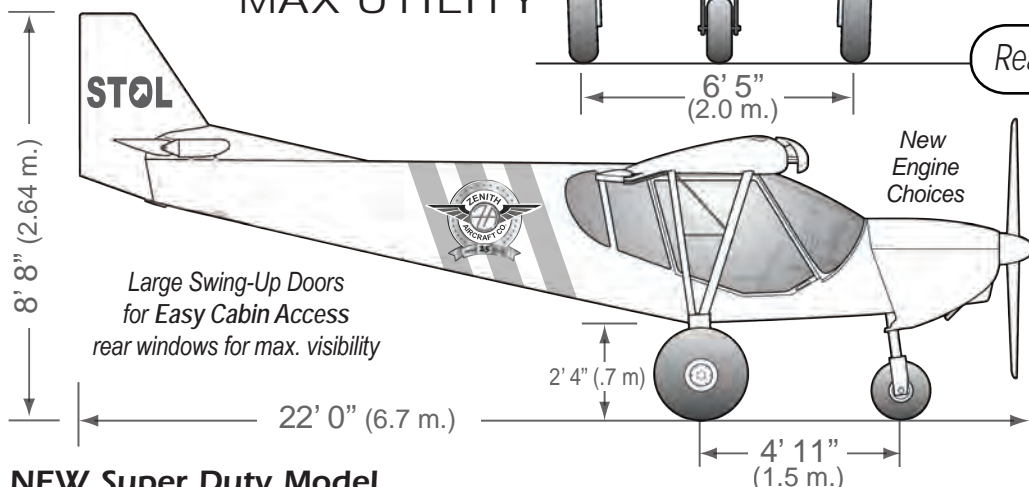

Based on thirty years of popular high wing STOL designs from legendary designer Chris Heintz, the new STOL CH 750 Super Duty design incorporates amazing short-field capabilities, while maximizing cabin size, adding a rear jump seat, and increasing load carrying capability compared to the original STOL CH 750.

**NEW Super Duty Model**  
"Two Plus One" Seats  
STOL Performance  
True Sport Utility

Build your own from:  
- Plans (drawings),  
- Component kits,  
- Complete Kits

**"Modern, Roomy, Robust"**

- KITPLANES Magazine

- Amazing short take-off and landing (STOL) performance
- Surprisingly efficient cruise
- Huge cabin, side-by-side seating
- Large baggage area with rear jump seat
- Spectacular wrap-around visibility
- Great bushplane capabilities
- Tricycle gear simplicity & effectiveness

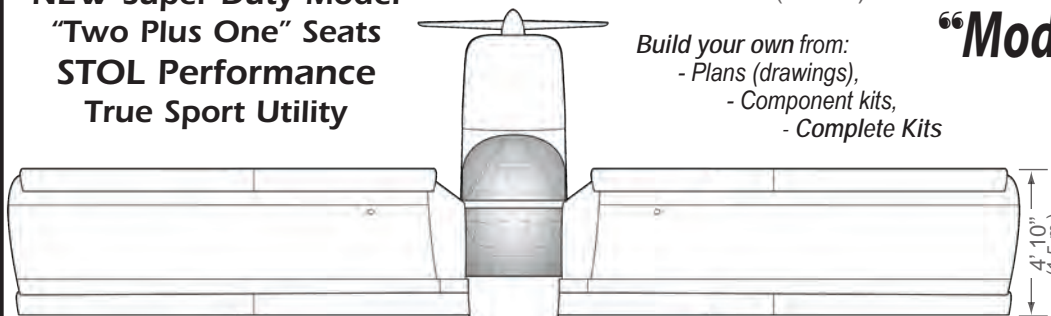

**NEW HIGHER GROSS WEIGHT!**

**New kit made with state-of-the-art CNC equipment**

Engine Choices:  
- Lycoming,  
- Continental,  
including Titan  
- auto conversions,  
and more...  
Suitable engines:  
150 - 230 hp

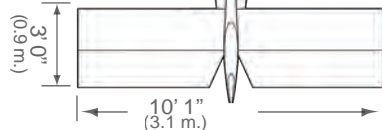

- ✦ Precision CNC cut and drilled parts.
- ✦ Extensive use of final hole size match-drilled assemblies.
- ✦ Factory-built and riveted main wing spars.
- ✦ CAD blueprints and detailed kit assembly instructions.
- ✦ Manufactured and supported in the USA.

AVAILABLE KIT OPTIONS include the new UnPanel repositionable glass panel (conventional instrument panel is standard), floats (straight or amphibious), BRS recovery system, upholstery kits, choice of wheels, and more!

ZENITH AIRCRAFT CO.  
1881 Airport Road, Mexico Airport,  
Mexico, Missouri 65265-0650 USA  
TEL: 573-581-9000 FAX: 573-581-0011



**BUILD IT. FLY IT!**

Visit us online for complete details  
**zenithair.com**

# STOL CH 750

# SPORT UTILITY KIT AIRPLANE

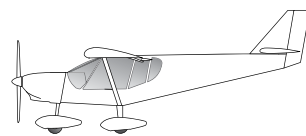
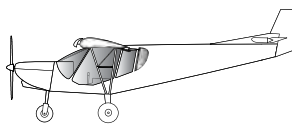
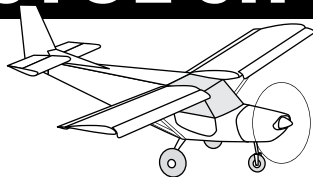

## SPECIFICATIONS

	STOL CH 750 SUPER DUTY	Sport Pilot ready STOL CH 750	The Faster CH 750 CRUZER
LENGTH	22 Ft. 0 In.	21 Ft. 10 In.	23 Ft. 6 In.
HEIGHT (rudder tip)	9 Ft. 0 In.	8 Ft. 8 In.	8 Ft. 11 In.
WING SPAN	33 Ft. 5 In.	29 Ft. 9 In.	29 Ft. 8 In.
WING AREA	162 Sq. Ft.	144 Sq. Ft.	147 Sq. Ft.
WING CHORD	4 Ft. 10 In.	4 Ft. 10 In.	4 Ft. 11 In.
HORIZONTAL TAIL SPAN	10 Ft. 1 In.	8 Ft. 5 In.	8 Ft. 4 In.
EMPTY WEIGHT	1,100 Lbs.	775 Lbs.	780 Lbs.
GROSS WEIGHT	1,900 Lbs.	1,320 Lbs. LSA Limit	1,320 Lbs. LSA Limit
DESIGN GROSS WEIGHT	1,900 Lbs.	1,440 Lbs.	1,440 Lbs.
USEFUL LOAD	800 Lbs.	545 Lbs. / 665 Lbs.	540 Lbs. / 660 Lbs.
FUEL CAPACITY (Standard)	48 US Gal.	24 US Gal.	30 US Gal.
WING LOADING	11.7 Lbs./Ft. <sup>2</sup>	9.2 Lbs./Ft. <sup>2</sup>	9.0 Lbs./Ft. <sup>2</sup>
POWER LOADING (with typical engine)	9.3 Lbs./BHP	12.6 Lbs./BHP	11.5 Lbs./BHP
DESIGN LOAD FACTOR	+6 / -3 G Ultimate	+6 / -3 G Ultimate	+6 / -3 G Ultimate
CABIN WIDTH (Shoulders, <u>without</u> bubble doors)	42 Inches	42 Inches	42 Inches
NEVER EXCEED SPEED (VNE)	145 MPH	125 MPH	145 MPH
SUITABLE POWER / Max Engine Weight	150 - 230 hp	100 - 160 hp / 350 lbs.	100 - 160 hp / 350 lbs.

## PERFORMANCE at Gross Weight

	CH 750 SUPER DUTY	STOL CH 750	CH 750 CRUZER
<i>Engine (as tested, other engines available):</i>	IO-375 - 205 hp @ 2500 rpm	Jabiru 3300 - 105 hp @ 2950 rpm	UL350iS - 115 hp @ 2900 rpm
TAKE-OFF ROLL	115 Ft.	100 Ft.	350 Ft.
LANDING ROLL	150 Ft.	125 Ft.	350 Ft.
MAX. LEVEL SPEED	115 MPH	105 MPH	125 MPH
CRUISE SPEED (75%)	105 MPH	100 MPH	118 MPH
STALL SPEED (Flaps Down)	35 MPH	35 MPH	39 MPH
RATE OF CLIMB	1,350 fpm	1,000 fpm	1,200 fpm
SERVICE CEILING	15,000+ Ft.	14,000+ Ft.	14,000+ Ft.
RANGE (Standard, no reserve) - ENDURANCE	630 miles 6 Hours	370 miles 3.7 Hours	500 miles 4.25 Hours

## KIT PRICING US Funds 4-2022

	STOL CH 750 SUPER DUTY	Light Sport Utility STOL CH 750	The Faster CH 750 CRUZER
<i>Airframe Kit</i>	\$ 29,975.	\$ 24,950.	\$ 23,975.
<i>Finishing Kit (firewall-back)</i>	\$ 9,995.	\$ 7,950.	\$ 7,750.
<i>Drawings and Manuals (included in kit)</i>	\$ 575.	\$ 575.	\$ 575.

Prices in US Funds. Prices and availability subject to change without notice.  
Prices are F.O.B. Factory. Crating and shipping charges are extra.

ZENITH AIRCRAFT CO.  
1881 Airport Road, Mexico Airport,  
Mexico, Missouri 65265-0650 USA  
TEL: 573-581-9000 FAX: 573-581-0011



Visit us online for complete details  
**zenithair.com**

Specifications and performance figures based on prototype results,  
with their respective installed engine, subject to change without notice.

CH 750 SD CRZ 4-22-master.pdf/ai