

# ZENITH CH 650 B



## Affordable Cruiser from Zenith Aircraft Company

### The affordable recreational kit aircraft for sport pilots:

The Zenith CH 650 is a second generation light sport aircraft, developed specifically for Sport Pilots. The Zenith CH 650B is the latest model from aeronautical engineer Chris Heintz, first introduced in 1984. This newest model offers new and updated features including modern styling with a larger cabin area. Modern kit manufacturing technology makes the CH 650 easier and quicker to build than ever!

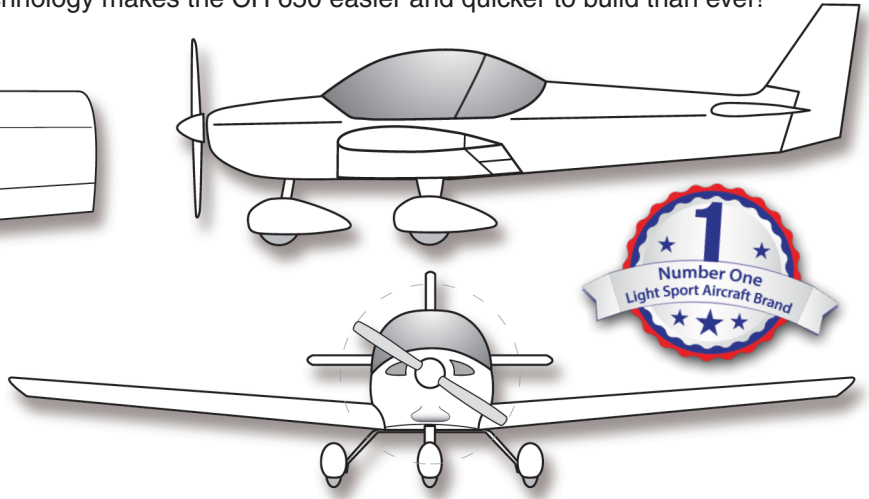
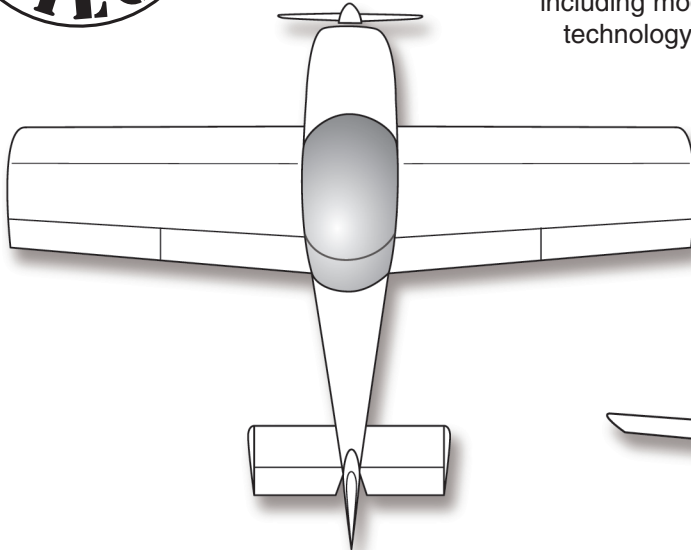

<b>PERFORMANCE</b>	MAX. CRUISE (sea level)	138 MPH	<b>SPECIFICATIONS</b>	WING SPAN	27 Feet
	STALL (with flaps)	44 MPH		LENGTH	20 Feet
	STALL (no flaps)	50 MPH		WING AREA	134 sq.ft.
	RATE OF CLIMB	1,200 FPM		CABIN WIDTH	44 Inches
	TAKE-OFF ROLL	500 FEET		EMPTY WEIGHT	695 lbs
	LANDING DISTANCE	500 FEET		DESIGN GROSS WEIGHT	1,320 lbs
	ENDURANCE (standard) <sup>1</sup>	4.8 HRS		FUEL CAPACITY - Standard	24 US Gal.

Performance figures with Jabiru 3300 engine: 110-hp @ 3,000 rpm. Specification and performance figures are based on standard factory prototype test results, and are subject to change and revision without prior notice. <sup>1</sup> Endurance figures given without fuel reserve.



- 👍 **The kit includes many precision CNC pre-cut and drilled components.**
- 👍 **All conventional solid riveting & welding is done at the factory**
- 👍 **CAD blueprints and detailed photo assembly manuals.**

**“I liked the CH650 a lot ... it offers exceptional value for the money.”**

– Pilot magazine

**Sport Pilot Ready:** \*Subject to meeting FAA rules as constructed by the builder. Zenith Aircraft Company cannot guarantee that the kit aircraft, as constructed by the builder, will meet the definition of a Light-Sport Aircraft. Larger and heavier engines and other installed equipment will limit the useful load of the aircraft, and may disqualify the aircraft from meeting the defined category limits.

**ZENITH AIRCRAFT CO.**  
 1881 Airport Road, Mexico Airport,  
 Mexico, Missouri 65265-0650 USA  
 TEL: 573-581-9000 FAX: 573-581-0011



**Build It. FLY IT!**

Visit us online for complete details  
**zenithair.com**

# ZENITH CH 650 B

The Updated ZODIAC from Zenith Aircraft Company



*"Simple to Build,  
Fun to Fly"*  
- KITPLANES magazine

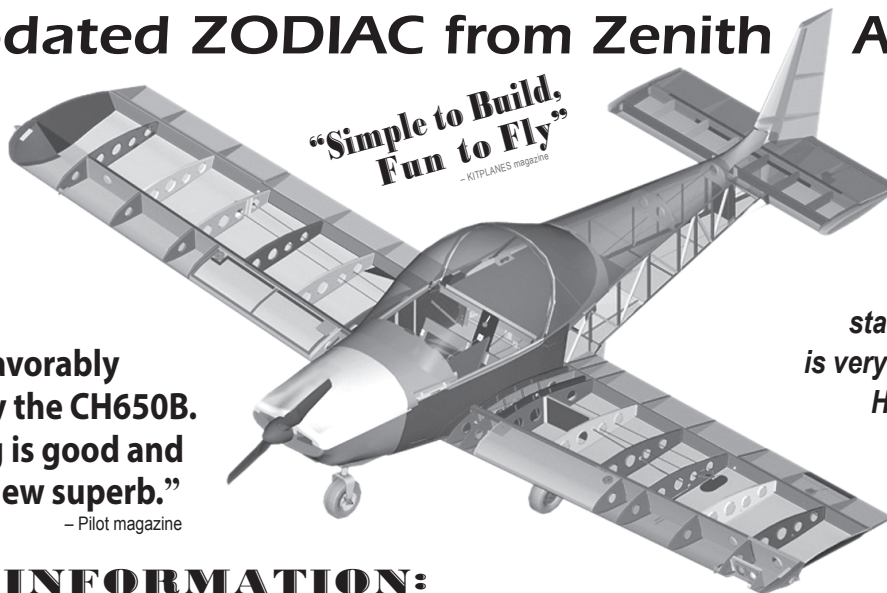

**"I was very favorably impressed by the CH650B. The handling is good and the field of view superb."**

- Pilot magazine

*"...a playful, delightful airplane with side-by-side seating and a gorgeous bubble canopy. Handling is great, stability is pleasant, and the kit is very straight forward. Highly recommended."*

*New upgraded features with modern styling*

## PRICE INFORMATION:

### Introductory Rudder "Starter Kit"

**\$ 375.00**

The Starter Kit includes the complete kit for the rudder tail section for the Zenith CH 650, and comes with a detailed and illustrated step-by-step assembly manual – everything you need to get started! Assembling the rudder Starter Kit is just a weekend project, and will provide you with an excellent 'hands-on' introduction to building your own aircraft. The Starter Kit can be shipped domestically by UPS. (The required assembly tools are available separately).

### ZENITH CH 650 B Drawings and Manual

**\$ 495.00**

Detailed blueprints of the complete Zenith CH 650 B airframe and detailed Photo Assembly Guides on CD-ROM, supplied with an aircraft serial number: All you need to 'scratch-build' the CH 650 or to preview and study the design and construction before purchasing the kit. The drawings and manuals are included with the complete airframe kit. Add \$25.00 for overseas Air Mail shipping. (Cost of the drawings is deductible from price of the complete kit).

### ZENITH CH 650 B Complete Kit

The updated Zenith CH 650 B airframe kit comes with all kit parts to build the airframe: The kit includes the factory riveted wing spars, pre-formed sheet-metal parts (ribs, skins, etc.), factory-welded parts, standard fuel tanks, controls, and hardware required for assembly of the airframe. The Drawings and Manual are included with the airframe kit. The standard Zenith CH 650 kit includes many precision CNC cut and drilled skins and components.

The Finishing Kit includes the items to complete the aircraft, including the spring gear, wheels with hydraulic disk brakes, the new formed bubble canopy, seat belts, electric elevator trim and electric flap actuator, finishing hardware, and more.

Not included in the kit: powerplant and instruments packages, paint, and upholstery.

**ZENITH CH 650 B Airframe Kit**

**\$ 20,495.00**

**ZENITH CH 650 B Finishing Kit**

**\$ 6,495.00**

### ZENITH CH 650 B "Quick Build Kit"

**\$ 32,785.00**

The new Zenith CH 650 Quick Build Kit provides an advanced level of pre-assembly of kit parts to save the builder valuable time and to further simplify kit assembly. In the Quick Build Kit, the main fuselage structure has been pre-assembled at the factory. Price FOB Factory. Limited Availability. Price includes Airframe and Finishing Kits.

### ZENITH CH 650 Component Kits

You may choose to purchase sections of the complete kit to 'buy-as-you-build' instead of ordering the complete airframe kit as a single package. The Drawings and Manuals must be purchased separately. Any individual airframe part or component is also available (for plans-builders).

Available kit options include dual control sticks, tail-wheel gear configuration, navigation/strobe lights, landing light, wheel fairings, long-range fuel system, aileron trim (electric), upholstery kit, and more. Firewall-forward powerplant packages are available for the ULPower UL350, Continental O-200, Rotax 912S, Jabiru 3300, and Lycoming O-235 engines, and other engine installations are possible including automotive conversions.

## ZENITH AIRCRAFT CO.

1881 Airport Road, Mexico Memorial Airport,  
Mexico, Missouri 65265-0650 USA

TEL: 573-581-9000 (8-5 Central, Mon-Fri)

FAX: 573-581-0011

Facebook.com/zenithair

Online Builder Community:  
[www.zenith.aero](http://www.zenith.aero)



**Build It. FLY IT!**

Visit us online for complete details

**zenithair.com**